

# New Product Notification



Formerly A. O. Smith Electrical Products Company



## OEM REPLACEMENT FOR CARRIER EXHAUST DRAFT BOOSTER BLOWER UNITS

### Features for both:

- Original OEM Replacement
- Sensor Assembly (50HJ 401 484) not included
- See Reverse Side for Additional Information
- Permanent Split Capacitor
- Capacitor Included
- Ball Bearings
- Thermally Protected
- 40°C Ambient
- Single Phase
- Insulation Class B
- UL Approved and CSA Certified

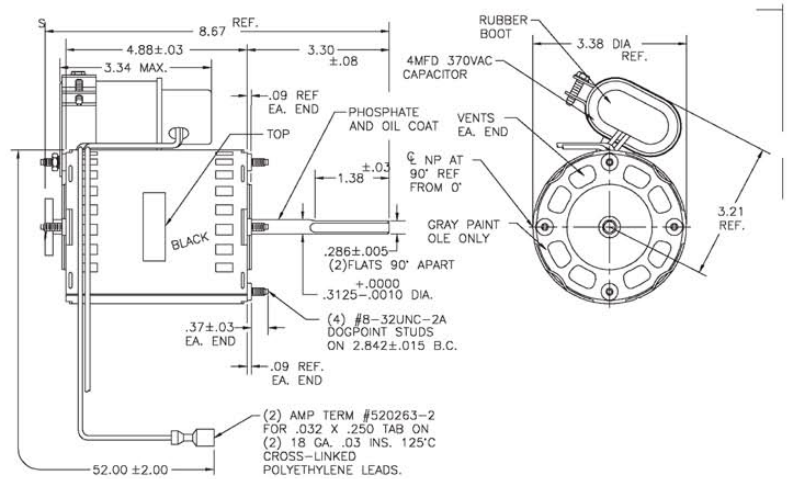

Stock No.	HP	Volts	Amps	RPM	Speeds	Frame	SF	HZ	Rotation	Wt.
9625	1/16	460	.25/.22	3450/2875	1	3.3	1.0	50/60	CCWSE	6.0
9626	1/16	208-230	.48	3450	1	3.3	1.0	60	CCWSE	6.0

**NOW AVAILABLE!  
FAX OR PHONE YOUR ORDER TODAY!**

A Regal Brand



# INSTALLATION INSTRUCTIONS

## STOCK NO. 9625 & 9626

**WARNING:** Motor should be installed by a qualified service technician in accordance with the National Electrical Code and other local codes which may apply.

**WARNING:** Always disconnect power supply before servicing or working on the motor for any reason.

CROSS REFERENCE	CENTURY	CARRIER	FASCO
STOCK NO. 9625 Replaces	JF1H101/JF1H091	HC30GB460/HC30GB462	D1184
STOCK NO. 9626 Replaces	JF1H102/JF1H092	HC30GB230/HC30GB232	D1182

1. Disconnect power supply
2. Disconnect motor wires
3. Remove motor frame from furnace
4. Remove sensor module (B) from defective motor (A)
5. Install sensor module (B) on replacement motor (C)
6. A new sensor module may be purchased from a Carrier Distributor as part number 50HJ401484
7. Install motor in unit
8. Connect motor wires and then electrical supply
9. Check operation

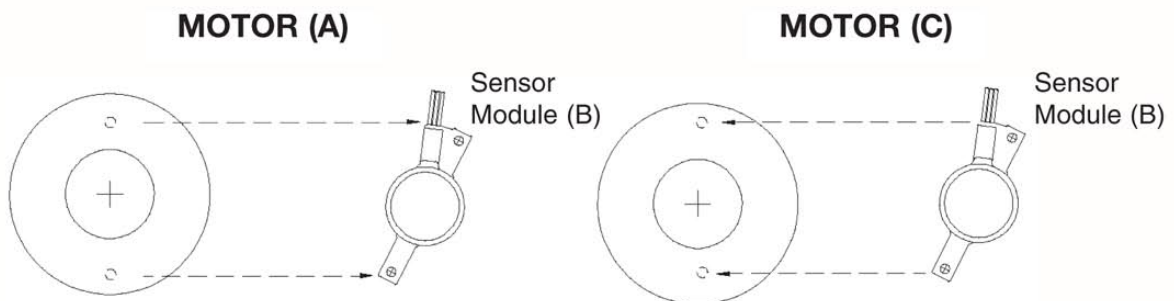

Universal Electric Motors  
6200 Dixie Road, Unit 1  
Mississauga, Ontario, L5T 2E1  
Tel: (905) 670-3380  
Toll Free: 1-877-670-3380  
Fax: (905) 670-7637 www.uem.ca

A Regal Brand

**REGAL**